

NEURO 2019

第42回 日本神経科学大会

The 42nd Annual Meeting of
the Japan Neuroscience Society

第62回 日本神経化学学会大会

The 62nd Annual Meeting of
the Japanese Society for Neurochemistry

飛翔する脳科学：
命と心の接点

Brain Science Takes Flight:
Bridging the Mind and Life

2019年7月25日(木) - 7月28日(日)
July 25-28, 2019

会場 朱鷺メッセ(新潟市) Venue: Toki Messe (Niigata)

第42回 日本神経科学大会 大会長

岡本 仁 (理化学研究所)

President: Hitoshi Okamoto (RIKEN)

第62回 日本神経化学学会大会 大会長

那波 宏之 (新潟大学)

President: Hiroyuki Nawa (Niigata University)

<http://www.neuro2019.jnss.org>



Sponsorship Prospectus

Greetings

We are pleased to announce that NEURO2019, the joint meeting of the 42nd Annual Meeting of the Japan Neuroscience Society and the 62nd Annual Meeting of the Japanese Society for Neurochemistry, will be held from July 25 (Thu) to 28 (Sun), 2019 at the Toki Messe Niigata Convention Center in the west coast of the main island of Japan. It has been six years since these organizations held the previous joint meeting in Kyoto in 2013.

Both societies were formed several decades ago with the aim of furthering understanding of the way the brain and nervous system function, with the Japan Neuroscience Society taking a neurophysiological approach and the Japanese Society for Neurochemistry, a neurochemical approach, and each making significant advances in their respective disciplines. Yet in recent years, studies of neural systems have increased in scope significantly, expanding beyond the traditional fields of biology, medical science and pharmaceutical science to cover the disciplines of economics, psychology, infotech, system engineering, education and chemistry as people try to use the knowledge of neuroscience to simulate trends in social behaviors and economic phenomena. Indeed, the borders that have separated realms of neuroscience and neural research are becoming increasingly murky. In light of such trends, the NEURO2019 joint meeting has been organized with the aim of bringing together a broad range of multidisciplinary fields of study.

With such impressive developments being made with modern neuroscience – such as molecular manipulation techniques for neurons and glial cells in the brain, control techniques for neural circuits, visualization methods of human brain activity, and computational neuroscience – we are gaining a better understanding of how the activities of groups of neural cells can regulate the various brain functions of “mind”, and we are elucidating the pathological mechanisms of neurological and psychiatric diseases. Under the general consensus that we, humans, have obtained these tools to reveal the fundamental ways how human brains operate, policy initiatives are taken by the governments around the world to promote further advances in brain research.

As neuroscience and neurochemical research continue to expand on a global scale, the Japan Neuroscience Society and the Japanese Society for Neurochemistry have organized NEURO2019 as a joint meeting with the theme of “Brain Science Takes Flight: Bridging the Mind and Life,” by focusing on the most recent developments in modern neuroscience and providing an avenue to discuss potential future developments. To achieve this goal, NEURO2019 will invite internationally distinguished researchers for plenary lectures and leading Japanese neuroscientists for special lectures, and medical education programs will also be implemented. An additional focus has been placed on training of young researchers, with the program such as oral presentations of young researchers, education-related seminars, and young scientist seminars. Thus, the Neuro2019 program will provide an extensive range of learning and discussion opportunities covering fundamental knowledge through to advanced fields catering to trainees through to graduate school students and researchers.

We would like to take this opportunity to provide the additional information below as We ask for your company’s cooperation and support for NEURO2019. We are looking forward to welcoming a large number of participants at the joint meeting. In closing, We offer my hopes for the continued growth and prosperity of your company.

Sincerely,

42nd Annual Meeting of the Japan Neuroscience Society
President Hitoshi Okamoto

62nd Annual Meeting of the Japanese Society for Neurochemistry
President Hiroyuki Nawa

Meeting Outline

- Title Joint conference of The 42nd Annual Meeting of the Japan Neuroscience Society and The 62nd Annual Meeting of the Japanese Society for Neurochemistry (Neuro2019)
- Theme Brain Science Takes Flight : Bridging the Mind and Life
- Date July 25 (Thu) – 28 (Sun), 2019
*The conference is scheduled to finish at 1:30pm and only educational lectures, symposia, and oral presentations are planned to be held on Day 4(July 28). Poster presentations, exhibition, and luncheon seminars are not programmed.
- Venue TOKI MESSE – Niigata Convention Center
- Purpose and Significance With such impressive developments being made with modern neuroscience – such as molecular manipulation techniques for neurons and glial cells in the brain, manipulation techniques for neural circuits, visualization methods of human brain activity, and computational neuroscience – we have been able to gain a better understanding of how the activities of groups of neural cells in the brain can be attributed to various functions of mind, and we have even been able to identify the pathological mechanisms of neurological and psychiatric diseases and use these findings for developing a way to treat them. Based on the consensus that we have obtained enough tools to reveal the fundamental way brains operate, many countries around the world are now taking the initiative to promote further advances in brain research.
Under such situations where Neuroscience and neurochemical research continue to expand on a global scale, the Japan Neuroscience Society and the Japanese Society for Neurochemistry have organized this joint meeting with the aim of promoting quantal leaps in neuroscience and neurochemistry research that extend beyond the traditional boundaries of such fields. To achieve this goal, the world’s leading researchers from a range of disciplines will present plenary lectures and special lectures, and symposiums and educational forums will be held to provide participants with a greater scope of the latest knowhow and advances, and facilitate communications among the researchers across research disciplines. A truly diverse program is being organized to run from early morning until late in the evening with the goal of boosting the level of “knowledge, technical prowess and interaction,” particularly for young trainees and those just starting out in the field of neuroscience.
- Program Plenary Lectures
Special Lectures
Symposia
Educational Lectures
Award Lectures
Oral / Poster Presentations
Luncheon Seminars
Exhibition
- Expected number of participants approx. 3,000

- Organizers

Presidents:

Hiroyuki Nawa	(Niigata University)
Hitoshi Okamoto	(RIKEN Center for Brain Science)

Executive Committee Chairs:

Hiroyuki Kamiguchi	(RIKEN Center for Brain Science)
Nobuyuki Takei	(Niigata University)

Executive Committee Members:

Carina Hanashima	(Waseda University)
Michihiro Igarashi	(Niigata University)
Kazutaka Ikeda	(Tokyo Metropolitan Institute of Medical Science)
Schuichi Koizumi	(University of Yamanashi)
Kenji Matsumoto	(Tamagawa University)
Masabumi Minami	(Hokkaido University)
Hirohide Takebayashi	(Niigata University)
Taro Toyoizumi	(RIKEN Brain Science Institute)

Program Committee Chairs:

Hitoshi Hashimoto	(Osaka University)
Yoshihiro Yoshihara	(RIKEN Center for Brain Science)

Program Committee Members:

Kaoru Amano	(Center for Information and Neural Networks)
Mutsuki Amano	(Nagoya University)
Taiju Amano	(Hokkaido University)
Jun Aruga	(Nagasaki University)
Hiroko Baba	(Tokyo University of Pharmacy and Life Sciences)
Haruhiko Bito	(The University of Tokyo)
Shigeyoshi Fujisawa	(RIKEN Center for Brain Science)
Ichiro Fujita	(Osaka University)
Fumino Fujiyama	(Doshisha University)
Tomoki Fukai	(RIKEN Brain Science Institute)
Toshiya Funabashi	(St. Marianna University School of Medicine)
Hidemasa Furue	(Hyogo College of Medicine)
Teiichi Furuichi	(Tokyo University of Science)
Yukiko Goda	(RIKEN Center for Brain Science)
Yukiko Gotoh	(The University of Tokyo)
Ritsuko Hanajima	(Tottori University)
Takashi Hanakawa	(National Center of Neurology and Psychiatry)
Ryota Hashimoto	(Osaka University)
Yasunori Hayashi	(Kyoto University)
Akiko Hayashi-Takagi	(Gunma University)
Hiroyuki Hioki	(Juntendo University)

Hajime Hirase	(RIKEN Center for Brain Science)
Shin-ichi Hisanaga	(Tokyo Metropolitan University)
Yoshio Iguchi	(Fukushima Medical University)
Takeshi Imai	(Kyushu University)
Kaoru Inokuchi	(University of Toyama)
Masaki Isoda	(National Institute for Physiological Sciences)
Yoshikazu Isomura	(Tamagawa University)
Shigeyoshi Itohara	(RIKEN Brain Science Institute)
Takuji Iwasato	(National Institute of Genetics)
Nobuhisa Iwata	(Nagasaki University)
Azusa Kamikouchi	(Nagoya University)
Tadafumi Kato	(RIKEN Brain Science Institute)
Takeshi Kawauchi	(Institute of Biomedical Research and Innovation)
Satoshi Kida	(Tokyo University of Agriculture)
Takefumi Kikusui	(Azabu University)
Kazuo Kitamura	(University of Yamanashi)
Katsunori Kitano	(Ritsumeikan University)
Yasuharu Koike	(Tokyo Institute of Technology)
Hiroshi Kuba	(Nagoya University)
Meigen Liu	(Keio University)
Naoki Matsuo	(Osaka University)
Masayuki Matsushita	(University of the Ryukyus)
Masanori Matsuzaki	(The University of Tokyo)"
Reiko Mazuka	(RIKEN Center for Brain Science)
Masaru Mimura	(Keio University)
Masayuki Miura	(The University of Tokyo)
Tsuyoshi Miyakawa	(Fujita Health University)
Kazunari Miyamichi	(RIKEN Center for Biosystems Dynamics)
Ikue Mori	(Nagoya University)
Kenji Morita	(The University of Tokyo)
Masanori Murayama	(RIKEN Center for Brain Science)
Junichi Nabekura	(National Institute for Physiological Sciences)
Katsuki Nakamura	(Kyoto University)
Kinichi Nakashima	(Kyushu University)
Yukio Nishimura	(Tokyo Metropolitan Institute of Medical Science)
Tadashi Nomura	(Kyoto Prefectural University of Medicine)
Sonoko Ogawa	(University of Tsukuba)
Mineki Oguchi	(Tamagawa University)
Kenich Ohki	(The University of Tokyo)
Toshihisa Ohtsuka	(University of Yamanashi)
Izumi Oinuma	(University of Hyogo)
Yoshitaka Oka	(The University of Tokyo)
Hiroyuki Okuno	(Kagoshima University)

Hiroataka Onoe	(HBRC, Kyoto University Graduate School of Medicine)
Rieko Osu	(Waseda University)
Minoru Saitoe	(Tokyo Metropolitan Institute of Medical Science)
Ko Sakai	(University of Tsukuba)
Takeshi Sakurai	(Kyoto University)
Makoto Sato	(Osaka University)
Kazunobu Sawamoto	(Nagoya City University)
Kazuhiko Seki	(National Center of Neurology and Psychiatry)
Katsuei Shibuki	(Niigata University)
Tomomi Shimogori	(RIKEN Center for Brain Science)
Wen-Jie Song	(Kumamoto University)
Hideaki Soya	(University of Tsukuba)
Tetsuya Suhara	(National Institutes for Quantum and Radiological Science and Technology)
Susumu Takahashi	(Doshisha University)
Takuya Takahashi	(Yokohama City University)
Kohtaro Takei	(Yokohama City University)
Sayaka Takemoto-Kimura	(Nagoya University)
Hideyuki Takeuchi	(Yokohama City University)
Toru Takumi	(RIKEN Center for Brain Science)
Masaki Tanaka	(Hokkaido University)
Saori C. Tanaka	(Advanced Telecommunications Research Institute International)
Miho Terunuma	(Niigata University)
Hiroaki Tomita	(Tohoku University)
Makoto Tsuda	(Kyushu University)
Makoto Urushitani	(Shiga University of Medical Science)
Ayako M. Watabe	(The Jikei University School of Medicine)
Masahiko Watanabe	(Hokkaido University)
Nobuhiko Yamamoto	(Osaka University)
Koji Yamanaka	(Nagoya University)
Hidenori Yamasue	(Hamamatsu University School of Medicine)
Yoko Yazaki-Sugiyama	(Okinawa Institute of Science and Technology Graduate University)
Toshiki Yoshimine	(Osaka University)
Yumiko Yoshimura	(NIPS, National Institutes of Natural Sciences)

Organization Committee Chair:

Katsuhiko Mikoshiba	(RIKEN Center for Brain Science)
---------------------	----------------------------------

Organization Committee Members:

Haruhiro Higashida	(Kanazawa University)
Teruhiko Higuchi	(National Center of Neurology and Psychiatry/Japan Depression Center)
Nobutake Hirokawa	(The University of Tokyo)
Sato Honma	(Hokkaido University/Sapporo Hanazono Hospital)
Kazuhide Inoue	(Kyushu University)
Takeshi Iwatsubo	(The University of Tokyo)

Kiyoto Kasai	(The University of Tokyo)
Mitsuo Kawato	(ATR Brain Information Communication Research Laboratory Group)
Yasushi Miyashita	(RIKEN Center for Brain Science)
Hidehiro Mizusawa	(National Center of Neurology and Psychiatry)
Toshitaka Nabeshima	(Fujita Health University)
Shigeo Okabe	(The University of Tokyo)
Hideyuki Okano	(Keio University)
Noriko Osumi	(Tohoku University)
Ryosuke Takahashi	(Kyoto University)

*as of June, 2018 / alphabetical order

● Budget *as of July, 2018

Income		
Item	Amount (JPY)	Remarks
1. Registration fees	38,930,000	2,860 participants, incl. reception
2. Seminar fees	8,856,000	7 seminars
3. Sponsorship package fees	6,240,000	3 packages
4. Exhibition fees	23,058,000	100 booths
5. Ad fees: Web banner	432,000	2 slots
Ad fees: Program booklet	1,512,000	11 pages
6. Subsidies and donations	21,000,000	Incl. grants from Niigata prefecture and foundations, etc.
7. Loan from the societies	3,000,000	
Total (JPY)	103,028,000	

Expenditure		
Item	Amount (JPY)	Remarks
1. Preparation expenses	<u>25,130,967</u>	
1) Personnel	9,535,000	
2) IT production	4,825,200	Incl. WEB and Abstract submission/Registration systems
3) Print/Production	9,140,135	Incl. Translation fees
4) Communication/Haulage	1,630,632	
2. Operational expenses	<u>68,703,790</u>	
1) Venue rental	17,570,557	
2) Equipments	24,137,661	
3) Personnel	9,458,100	
4) Invitation	7,070,535	
5) Meeting	8,081,780	
6) Sundry	2,385,157	
3. Post-meeting expenses	<u>5,612,490</u>	
4. Reserve fund	<u>3,580,753</u>	
Total (JPY)	103,028,000	

Sponsorship Package

Sponsorship Package

Platinum / Gold / Silver sponsorship packages are available.

Application deadline for sponsorship package: March 15 (Fri), 2019

Platinum JPY2,700,000 (excl. tax)

●The package offers

			(JPY, excl.tax)
1	Luncheon seminar	×1 Highest priority of date & room	1,300,000 - 1,700,000
2	Exhibition booth (A)	×5 Highest priority of booth allocation	1,150,000
3	Web banner	×1	200,000
4	Meeting badge	×5 (incl. participation in the reception)	100,000
5	Slide projection during an intermission at all lecture rooms and exhibition/posters site		100,000
Total Value			2,850,000 - 3,250,000

Gold JPY2,100,000 (excl. tax)

●The package offers

			(JPY, excl.tax)
1	Luncheon seminar	×1 Higher priority of date & room	1,300,000 - 1,700,000
2	Exhibition booth (A)	×2 Higher priority of booth allocation	460,000
3	Web banner	×1	200,000
4	Meeting badge	×3 (inc. participation in the reception)	60,000
5	Slide projection during an intermission at all lecture rooms and exhibition/posters site		100,000
Total Value			2,120,000 - 2,520,000

Silver JPY1,500,000 (excl. tax)

●The package offers

			(JPY, excl.tax)
1	Luncheon seminar	×1 High priority of date & room	1,300,000
2	Exhibition booth (A)	×1 High priority of booth allocation	230,000
3	Web banner	×1	200,000
4	Slide projection during an intermission at all lecture rooms and exhibition/posters site		100,000
Total Value			1,830,000

Application for sponsorship package: Please fill out the application form and send it to the secretariat below by March 15 (Fri), 2019.

Neuro2019 Secretariat (c/o A&E Planning Co., Ltd.)
Hitotsubashi Bekkan 4F, 2-4-4, Hitotsubashi, Chiyoda-ku, Tokyo 101-0003 Japan
E-mail: e_neuro2019@aeplan.co.jp TEL: +81-3-3230-2744

* Priorities will be given on a first-come-first-served basis within each package.

* Additional booths other than one(s) included in package are available at JPY230,000 (excl.tax) per booth.

* Please refer the details of each benefit to the following pages.

Luncheon Seminar

Luncheon Seminar

Luncheon seminars will be co-hosted with Neuro2019.

- Room Lecture / Session rooms of Neuro2019
- Language Japanese / English
- Date & Time July 25 (Thu) – 27 (Sat), 2019
Slot: 60 minutes (around lunchtime)
3 – 6 seminars per day will be held in parallel at the same time.
The number of seminars will vary depending on applications.
*Slot may change due to the program.
- Application Please fill out the application form and send it to the secretariat below by E-mail. Please note that no cancellations are accepted once we receive your application form.
An invoice will be sent by e-mail after the application form is received.
Please make a full payment by the due date written on the invoice.
* Bank charges shall be borne by the applicant.
* Check / Bill payments are not acceptable.
- Secretariat **Neuro2019 Secretariat** (c/o A&E Planning Co., Ltd.)
Hitotsubashi Bekkan 4F, 2-4-4, Hitotsubashi, Chiyoda-ku, Tokyo
101-0003 Japan
E-mail: e_neuro2019@aeplan.co.jp TEL: +81-3-3230-2744
- Application deadline March 15 (Fri), 2019
- Disclosure of information Sponsors agree to disclose their contributions.
- Room & Fee

Date	Slot (tentative)	Capacity (tentative)	Fee (excl. tax)
July 25(Thu)	12 : 20 – 13 : 10	500	JPY1,700,000
	12 : 20 – 13 : 10	200	JPY1,500,000
	12 : 20 – 13 : 10	100	JPY1,300,000
July 26(Fri)	12 : 00 – 12 : 50	500	JPY1,700,000
	12 : 00 – 12 : 50	200	JPY1,500,000
	12 : 00 – 12 : 50	100	JPY1,300,000
July 27(Sat)	12 : 00 – 12 : 50	500	JPY1,700,000
	12 : 00 – 12 : 50	200	JPY1,500,000
	12 : 00 – 12 : 50	100	JPY1,300,000

*Please note that organizers will arrange allocation of date and room based on each applicant preference written on the application form.

- Notes
- Equipment

Seminar fee provides standard audio-visual equipment for seminar (projector, screen, microphone, etc.) and staff for video, audio, and lighting. **Also, one meeting badge is to be provided for free access to programs at the venue.** If any other equipment, such as video recording or tape recording is required, charges will be incurred separately. Please contact the secretariat for the details.
- Program

Program will be organized by the executive committee and informed to the seminar hosts from the secretariat.
- Seminar fees do not include the following items and options. Actual cost will be charged as option expenses by the secretariat after the meeting.

- Box lunch for participants (with drink)

Please arrange lunch box as seminars will be held during lunchtime.

The secretariat will confirm a quantity of box lunch with each seminar host after the application deadline, and handle the orders.

Price of box lunch with drink (tentative): JPY1,300 / box.

- Options

1. Personnel expense: operational staff (announcement, timekeeping, distribution of materials and lunch, guide)

*They will be arranged separately from staff assigned to other program.

2. Honorarium and travel expenses for speakers and chairs

3. Signboard and display at the entrance of seminar room, etc.

4. Additional equipment: video recording / tape recording / simultaneous interpretation / equipment for anteroom, etc.

5. Anteroom: room charge, food and drink

6. Agent service fee

*If you order above options, 10% of agent service fee will be added to the total amount of option fees.

- **Advance reservation system** will be available online for the luncheon seminars of Neuro2019. The information of participants who made a reservation will be provided to each seminar host. The schedule and procedure will be notified from the secretariat after the application.

<Attention on personal information acquisition and system usage>

Please confirm the following and tick on the application form.

1. We never sell or share the personal information.
2. We use the personal information only within the company unless the person agrees.
3. We stop using the personal information when the person denies providing the information or contacting.
4. We assign a supervisor and take precautions against loss and leak of the personal information.
5. We delete and never use the personal information that clearly seems to be an error.
6. We take appropriate measures based on the Act on the Protection of Personal Information.

Advertisement

Program Booklet

Web Banner

On-screen Ad

Flyer Distribution Board

Symposium co-sponsored Presentation

Advertisement in Program Booklet

- Book title Neuro2019 Program
- Book size, Printing method, etc.
A4 (297 mm height × 210 mm width), approx. 400 pages
Offset printing (Front cover: four colors / Body: black and white),
Perfect binding
- Circulation 3,700
- Distribution to Participants in Neuro2019
- Budget JPY 4,995,000
- Rate Please note that organizers will decide allocation of ads in back matter.

Space	Size	Color	Rate (excl. tax)	Space available
Back cover	A4 : 1 page	4 colors	JPY 500,000	1
Inside front cover	A4 : 1 page	Black and White	JPY 250,000	1
Inside back cover	A4 : 1 page	Black and White	JPY 250,000	1
Back matter 1 page	A4 : 1 page	Black and White	JPY 150,000	up to 10
Back matter 1/2 page	A4 : 1/2 page	Black and White	JPY 80,000	up to 10

- Application Please fill out the application form and send it to the secretariat below by e-mail.
- Application deadline March 29 (Fri), 2019
- Ad submission deadline April 10 (Wed), 2019
- Ad size 1 page: 255 mm height × 180 mm width
1/2 page: 120 mm height × 180 mm width
*Bleed is not acceptable in either four colors or black and white.
- Ad requirements Print-ready data – four colors / black and white *Please attach a print sample.
○ Format
 1. Adobe illustrator: All fonts should be outlined, and all images should be embedded. Also, please specify your OS and the version of Illustrator used for creating the ad. Proofreading will be performed by the printer. Please note that a proof sheet will not be sent to you.
 2. PDF: All fonts should be outlined, and all images should be embedded. If MS-Word or MS-PowerPoint is used for creating the ad, please make sure to specify the application used. Please note that submitted data may not be accepted.
- Ad submission Please send ad data to the secretariat by e-mail.
- Payment An invoice will be sent to you by e-mail after the application form is received.
Please make a full payment by the due date written on the invoice.
- Disclosure of information Sponsors agree to disclose their contributions.
- Secretariat **Neuro2019 Secretariat** (c/o A&E Planning Co., Ltd.)
Hitotsubashi Bekkan 4F, 2-4-4, Hitotsubashi, Chiyoda-ku, Tokyo
101-0003 Japan
E-mail: e_neuro2019@aeplan.co.jp TEL: +81-3-3230-2744

Web Banner

- Name of advertisement media Website of Neuro2019
- Type of advertisement media Online advertisement by web banner
- Home page [http:// www.neuro2019.jnss.org](http://www.neuro2019.jnss.org)
*Available from July 2018 (tentative)
- Number of spots approx. 10
- Placement method Random placement – banners appear when the website is visited.
- Advertisement rate JPY 200,000 (excl. tax) per spot
- Application Please fill out the application form and send it to the secretariat below by e-mail.
- Viewing period Applications will be accepted after the website is launched in July 2018.
Placement is guaranteed until 1 month after the meeting.
- Banner size Height 80 pixels × Width 228 pixels
- Format
 1. File type: GIF (Animation GIF, Infinite loop are acceptable) / JPEG
 2. File size: within 50 KB
 3. Please note that no change in banner design will be accepted after placement.
- Banner submission Please submit GIF/JPEG file meeting the above requirements, together with URLs for affiliate links. Banner will be placed within 7 business days after receipt. Please send a banner to the secretariat by e-mail.
- Payment An invoice will be sent after the application is received. Please make a full payment by the due date into the bank account indicated on the invoice.
Note: Bank fees shall be borne by the applicant.
- Disclosure of information Sponsors agree to disclose their contributions.

- Secretariat

Neuro2019 Secretariat (c/o A&E Planning Co., Ltd.)
Hitotsubashi Bekkan 4F, 2-4-4, Hitotsubashi,
Chiyoda-ku, Tokyo 101-0003 Japan
E-mail: e_neuro2019@aeplan.co.jp
TEL: +81-3-3230-2744



On-screen Ad

- Name of advertisement media Neuro2019 on-screen ad
- Type of advertisement media Ad projection on a screen
- Description Ad will be projected on the screen broadcasting lectures live at the exhibition site when there is no lecture.
- Number of spots approx. 10 (60 seconds per 1 ad)
- Display method Loop
- Advertisement rate JPY 100,000 (excl. tax) per spot
- Application Please fill out the application form and send it to the secretariat below by e-mail.
- Application deadline May 17(Fri), 2019
- Viewing period While the screen is not in use for broadcasting lectures live during the exhibition.
- Format Microsoft PowerPoint (Resolution: XGA / Aspect ratio: 4:3)
- Ad submission Please send an ad data to the secretariat by e-mail.
- Disclosure of information Sponsors agree to disclose their contributions.

Flyers Distribution Board for co-sponsors

- Name of advertisement media Flyers distribution board for co-sponsors
- Type of advertisement media Leaflet and flyer up to A4-size
- Description A panel will be available for distributing flyers at the poster/exhibition site. Please use it for promoting your new products/service or introducing your booth.
- Co-sponsor fee JPY 30,000 (excl. tax) per spot
- Application Please fill out the application form and send it to the secretariat below by e-mail.
- Application deadline April 19(Fri), 2019
- Location Exhibition hall, TOKI MESSE (Poster/Exhibition site)
- Equipment Please prepare the flyers (up to A4-size) by applicants.
- Disclosure of information Sponsors agree to disclose their contributions.
- Secretariat **Neuro2019 Secretariat** (c/o A&E Planning Co., Ltd.)
Hitotsubashi Bekkan 4F, 2-4-4, Hitotsubashi,
Chiyoda-ku, Tokyo 101-0003 Japan
E-mail: e_neuro2019@aeplan.co.jp
TEL: +81-3-3230-2744

Symposium co-sponsored Presentation

Neuro2019 offers an opportunity to make a 3-minute presentation; “symposium co-sponsored presentation” at a lecture room before each symposium starts. It can be used for PR of your company, products, exhibition booth, etc. Symposium is selectable. Please take advantage of this opportunity.

- Qualification Exhibitors or Luncheon seminar hosts
- Presentation Only 1 presentation per symposium is acceptable.
Presentation time is for 3 minutes.
The symposium can be chosen on a first-come-first-served basis.
Application for more than one symposium is available.
- Fee JPY30,000 (tax excluded) / symposium
- Application Please fill out the application form and send it to the secretariat below by e-mail.
- Application deadline May 17(Fri), 2019
- Disclosure of information Sponsors agree to disclose their contributions.
- Secretariat **Neuro2019 Secretariat (c/o A&E Planning Co., Ltd.)**
Hitotsubashi Bekkan 4F, 2-4-4, Hitotsubashi,
Chiyoda-ku, Tokyo 101-0003 Japan
E-mail: e_neuro2019@aeplan.co.jp
TEL: +81-3-3230-2744

* Details of symposia will be released later.

Exhibition

Exhibition

- Schedule
 - July 24 (Wed), 2019 2:00 pm – 5:00 pm (Set-up)
 - 25 (Thu), 2019 9:00 am – 5:00 pm
 - 26 (Fri), 2019 9:00 am – 6:30 pm
 - 27 (Sat), 2019 9:00 am – 5:00 pm (Dismantling 5:00 pm –)

*Above schedule may be changed. Please confirm a “Confirmation notice” sent around 1 month before Neuro2019.
- Venue TOKI MESSE – Exhibition Hall
- Acceptable exhibits Devices, Reagents, Disposable products, Computer system including software or database, Technical service, PR activity of University or Research institution, Other services for research, Related books, Translation service, etc.
Exhibits not included in above are not acceptable.
- Number of booth 100 booths offered
- Application

Please apply via online application system linked below;
<https://reg26.smp.ne.jp/regist/is?SMPFORM=qam-ninfn-6de0594e7d6746af8466fa3ebf6ec20d>

 - 1) Please confirm an automatic reply sent from the system after submission.
 - 2) An acceptance notice will be sent from the secretariat by e-mail.

Your application is completed when both 1) and 2) are done.
Applications from unrelated companies or exhibits not listed above will be discussed first, and the secretariat will send the conclusion by e-mail.
If you can not apply via the online application system, please contact the secretariat below by e-mail.
- Application deadline April 19 (Fri), 2019
- Payment due June 28 (Fri), 2019

*In case that you cannot pay by the due date after receipt of an invoice, please make sure to inform us. Otherwise, your application will be cancelled and a cancellation charge will be incurred.
- Cancellation

Once your application is received, no cancellation will be accepted except in an inevitable accident recognized by the organization committee. Even in case the cancellation is accepted, a notice in writing must be sent to the secretariat and a cancellation charge will be applied as below based on the receiving date of the notice.

Notice before April 19 (Fri), 2019	…
	50% of the total fee (Exhibition fee)
Notice on and after April 19 (Fri), 2019	…
	100% of the total fee (Exhibition fee)
- Secretariat

Neuro2019 Secretariat (c/o A&E Planning Co., Ltd.)
Hitotsubashi Bekkan 4F, 2-4-4, Hitotsubashi, Chiyoda-ku, Tokyo 101-0003 Japan
E-mail: e_neuro2019@aeplan.co.jp
TEL: +81-3-3230-2744

- Booth allocation
Booths will be allocated upon due consideration of kinds of exhibits, shapes, weight, a number of booths, etc. after the application deadline and a layout will be sent with a confirmation notice. No booth allocation meeting will be held.
*Please let us know if you have any requests until the application deadline.
(ex. To allocate booths side-by-side with group companies or business partners.)
- Display table
In case you do not need display tables and place exhibits directly on the floor, please specify the number of unnecessary table on the application system.
Also, please tick the specified section if you are planning your own special decorations for your booths.
- Exhibits control
Please be reminded that all exhibits are under exhibitors' control, and we are not responsible for any losses, thefts, fire or damages by an inevitable accident during the exhibition.
- Others
Distributing flyers, catalogues or samples apart from your booth during the exhibition is not permitted. Since many companies are expected to participate in the exhibition, your cooperation would be highly appreciated.
However, there will be some exceptions of an extra fee option to distribute or with permission from the organization committee.
- Contributions
A part of exhibition fee will be used for arranging "Stamp rally"(Prizes etc.) which is to be held at the exhibition site. If you are interested in cosponsoring prizes, please contact the secretariat.

- Booth type & Fee

- Type A JPY230,000 (excl. tax) / booth

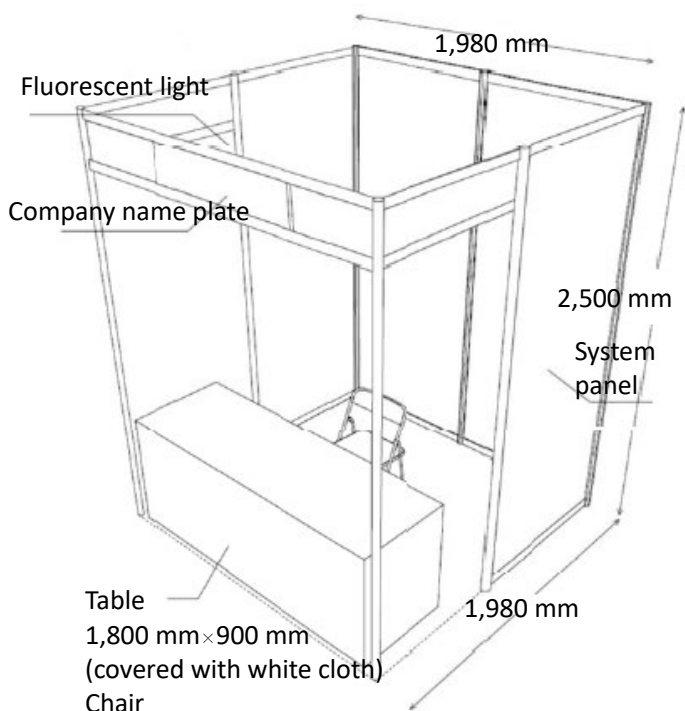

- Acceptable exhibitor

Companies and organizations dealing in devices, reagents, disposable products, computer system including software/database, and technical service related to research in medical and life sciences.

- Booth size

W1,980 mm × D1,980 mm × H2,500 mm

- Furniture

Display table covered with a white cloth (W1,800 mm × D900 mm × H720 mm), Company name plate, Fluorescent light (40W), 1 chair (It depends on the number of booth.), and 4 exhibitor's name badges per booth.

- System panel booth. Pushpins and nails are not available on the panels.

- Type B1 JPY30,000 (excl. tax) / booth

- Acceptable exhibitor

Publishers dealing in related books.
Companies and organizations offering translation service.

- Booth size

W1,800 mm × D600 mm

- Furniture

Display table (W1,800 mm × D600 mm), 1 chair, and 4 exhibitor's name badges per booth.

*Please prepare a company name plate, a tablecloth, etc. by yourself.

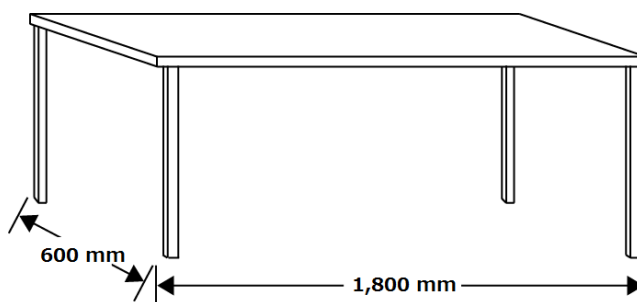

- Type B2 JPY10,000 (excl. tax) / booth

- Acceptable exhibitor

Only book stores dealing in related books.

* Booth size and furniture are the same as type B1.

- Type C JPY100,000 (excl. tax) / booth

* Booth spec is the same as Type A.

- Acceptable exhibitors

Academic institutions, Universities, public institutions, etc.

- Booth size

W1,980 mm × D1,980 mm × H2,500 mm

- Furniture

Display table covered with a white cloth (W1,800 mm × D900 mm × H720 mm), Company name plate, Fluorescent light (40W), 1 chair (It depends on the number of booth.), and 4 exhibitor's name badges per booth.

- System panel booth. Pushpins and nails are not available on the panels.

◆ **Electricity is optional, please order via the online application system if needed.** Installation work charge for electric power supply equipment and electricity charge will be billed to each exhibitor.

Neuro2019

Application form for Sponsorship Package

Application Deadline: March 15, 2019

Date:

Company name		
Address	(Postal / ZIP code: _____) Address	
Person in charge	Name	TEL
	Division	FAX
	E-mail address * Please make sure to fill in a valid e-mail address.	

We have confirmed and consented to the <Attention on personal information acquisition and system usage>.

◆ Please choose a sponsorship package and fill in your preference for the date and capacity (both first and second choice).

◇ Sponsorship package (check the box of your choice)

<input style="width: 20px; height: 20px;" type="checkbox"/> Platinum	<input style="width: 20px; height: 20px;" type="checkbox"/> Gold	<input style="width: 20px; height: 20px;" type="checkbox"/> Silver
--	--	--

◇ Luncheon seminar

*ex. First choice: July 25 / Capacity 500

First choice: July _____ / Capacity _____

Second choice: July _____ / Capacity _____

* Priorities will be given on a first-come-first-served basis within each package.

* Additional booths other than one(s) included in package are available at JPY230,000 (excl.tax) /booth. Also, electricity of the exhibition booth is optional. If you wish, please contact the secretariat.

* Please refer to each section for the details of benefit included in each sponsorship package.

Message / Inquiries (if any)

● Send to: Neuro2019 Secretariat (c/o A&E Planning Co., Ltd.)

E-mail. e_neuro2019@aeplan.co.jp / TEL. +81-3-3230-2744

Neuro2019

Application form for Luncheon Seminar

Application Deadline: March 15, 2019

Date:

Company name		
Address	(Postal / ZIP code: _____) Address	
Person in charge	Name	TEL
	Division	FAX
	E-mail address * Please make sure to fill in a valid e-mail address.	

We have confirmed and consented to the <Attention on personal information acquisition and system usage>.

1. Session Please fill in your preference for the date and capacity (both first and second choice).

*ex. First choice: July 25 / Capacity 500

First choice: July _____ / Capacity _____ / Fee: JPY _____ (excl. tax)

Second choice: July _____ / Capacity _____ / Fee: JPY _____ (excl. tax)

2. Program (tentative)

Theme:

Speaker:

Name _____ Affiliation _____

Chair or Moderator: Chair Moderator

Name _____ Affiliation _____

Message / Inquiries (if any)

● Send to: Neuro2019 Secretariat (c/o A&E Planning Co., Ltd.)
E-mail. e_neuro2019@aeplan.co.jp / TEL. +81-3-3230-2744

Neuro2019

Application form for Advertisement

Application Deadline for Program booklets : April 10, 2019

Date:

Company name		
Address	(Postal / ZIP code: _____) Address	
Person in charge	Name	TEL
	Division	FAX
	E-mail address * Please make sure to fill in a valid e-mail address.	

We hereby apply for:

- Advertisement in Program Booklets

Space: _____ Rate: JPY _____ (excl. tax)

- Web Banner on Neuro2019

_____ Spot(s) Rate: JPY _____ (excl. tax)

- On-screen Ad

_____ Spot(s) Rate: JPY _____ (excl. tax)

- Flyers Distribution Board for co-sponsors

_____ Spot(s) Fee: JPY _____ (excl. tax)

Message / Inquiries (if any)

Neuro2019

Application form for Symposium co-sponsored Presentation

Application Deadline: May 17, 2019

Date: _____

We hereby apply for Symposium co-sponsored Presentation as follows;

Company name: _____

Person in charge:

Name _____

Tel _____ e-mail _____

Symposium

◆ 1st Choice

Session No. _____ Date _____ Time _____

Session Title _____

◆ 2nd Choice

Session No. _____ Date _____ Time _____

Session Title _____

Message / Inquiries (if any)